

# estron T2™

estron

## Audio Connector System for Earphones and Earpieces



## Strong and Reliable Connection - Fewer Repairs

Cable and socket problems are the most common points of failure for in-ear monitors and earpieces. The patented estron T2™ plug - socket Connector System solves the well-known intermittency issues with a strong and reliable electrical connection. Key words are high pull/tensile strength and a high reliability. With a much lower failure rate, the T2 is a proven alternative to other standard connector solutions.

Supplied in a minimalist and aesthetic design the T2 socket is easy to integrate. Combined with a strong tactility perception, the connector system contributes to the best possible end-user experience; easy to use, clear sound transmission, and long durability.

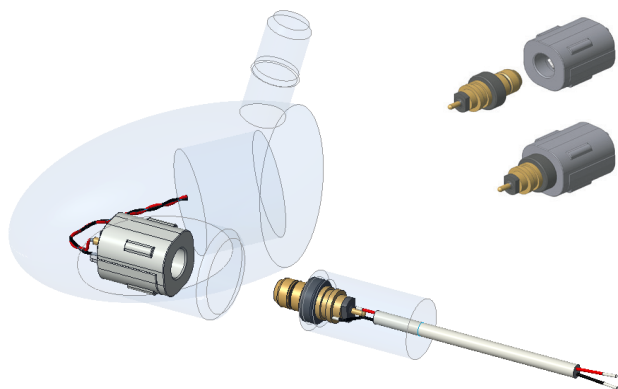

- No intermittence even with heavy use
- Consistent high durability
- Pull force stability
- Miniature design
- Minimal socket wear
- Metal parts resistant to extreme sweat exposure
- Sealed connector system (IP-68 2m water)
- Strong tactility perception
- Easy to integrate in design and product
- Tested and approved for medical devices

## Designed to Secure Longest Product Lifetime

To endure heavy-duty usage and contribute to prolonged product lifetime, the T2 Connector System is designed for minimum wear on the socket. Crafted like a talon, the T2 Socket DS (Dual Spring) features four robust connection points. Extensive testing demonstrates a solid connection even after 10,000 insertions, showing no intermittence, stable pull force and consistent tactility.

The connector system was originally designed in 2016 for the medical industry, and since then used in millions of audio applications. The T2™ Connector System is designed and patented by estron a/s.

Contact [sales@estron.dk](mailto:sales@estron.dk) for more information.

